

# Vortex 2 Voice Amp Instructions

## Hyperdyne Labs, © 2001-2007

<http://www.hyperdynelabs.com>

The included CD contains instructions for your Vortex 2 unit. Please print out the documentation. The documents are in Adobe PDF format, so you will need the free Acrobat reader available from [www.adobe.com](http://www.adobe.com)

*Your kit was manufactured using the highest-grade components available, please handle it with care as not to damage any of the components from static electricity. If you are not familiar with static electricity handling procedures, please refer to ESD procedures. Basic information on ESD can be found here: [http://en.wikipedia.org/wiki/Electrostatic\\_discharge](http://en.wikipedia.org/wiki/Electrostatic_discharge)*

### QUICKSTART connection guide

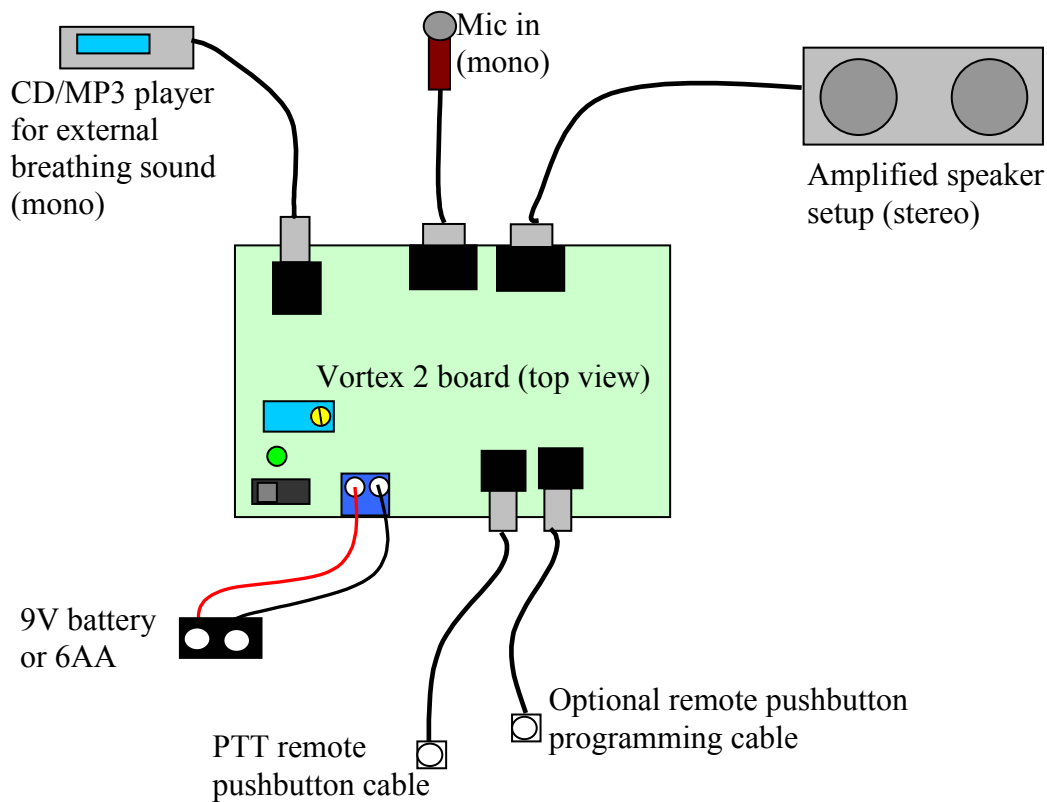

**NOTICE:** There is no warranty on kits. It is your responsibility to install the board. Opened kits cannot be returned. Be careful if you plan to use a battery source that is capable of delivering a lot of current. Contact a professional if you need assistance. Hyperdyne Labs assumes no responsibility for the misuse of this kit.